

SINGLE CRYSTAL PRODUCTS 2024

SINGLE CRYSTAL DIFFRACTION

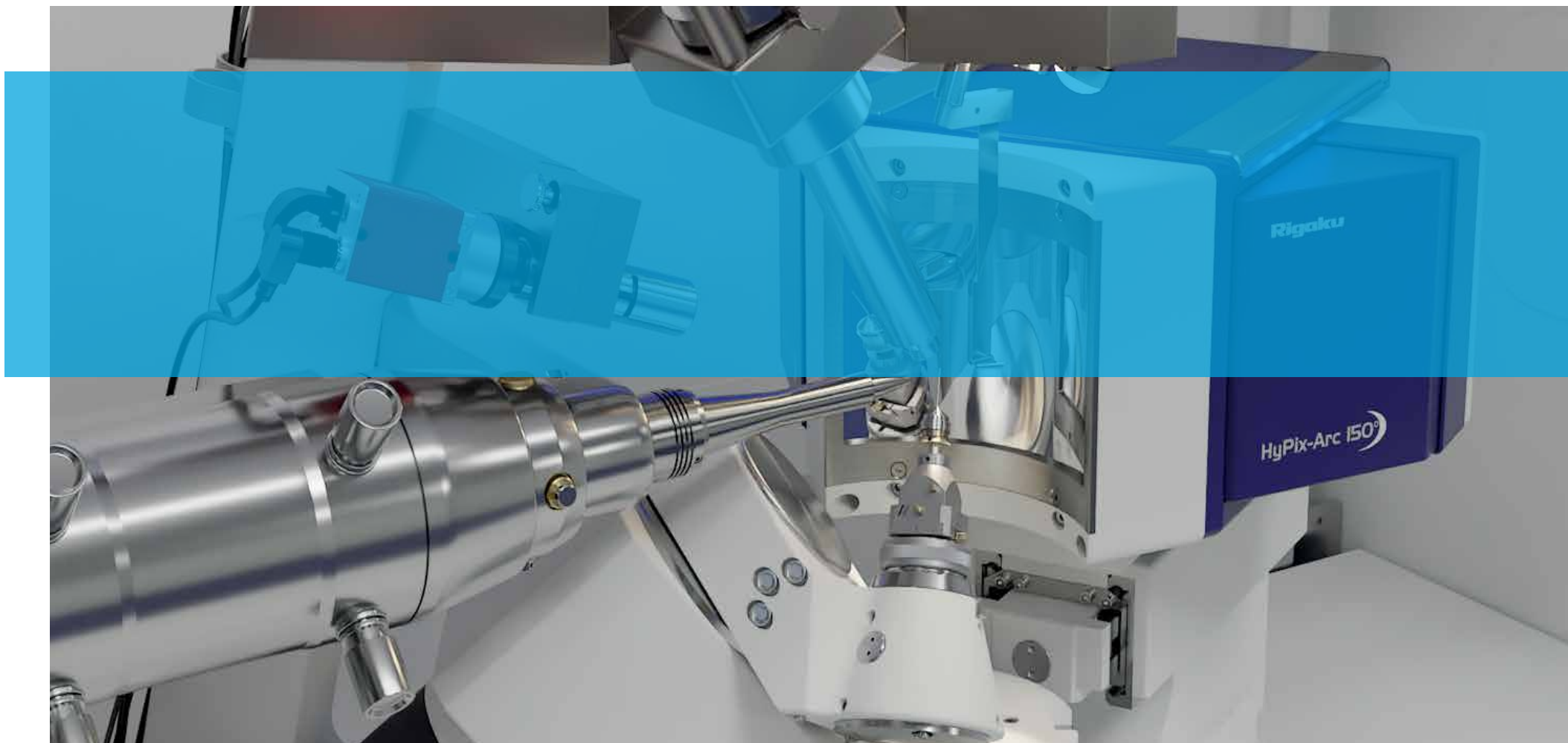

WHY CHOOSE RIGAKU OXFORD DIFFRACTION?

WHO ARE WE?

Rigaku employs over 1,800 staff world-wide, bringing together expertise from all corners of the globe. With major research and development sites in Japan, Europe and the U.S., we develop every core technology in-house, including X-ray sources, optics, detectors, goniometers and software.

We believe that this way we can provide a complete, tightly integrated solution that offers extreme performance and user friendliness.

We take a rigorous scientific approach to product development to continually improve our products and to incorporate new approaches and find new applications of our technology. Craftsmanship and ingenuity go hand-in-hand, resulting in our respected, reliable range of single-crystal X-ray diffractometers.

When you buy from Rigaku Oxford Diffraction, you are getting more than just a diffractometer.

WORLD-CLASS SCIENTIFIC SUPPORT

High-quality instrumentation is only as good as the user running it. That's why, following installation of your new system by one of our highly trained engineers, we provide face-to-face, personalized, on-site training by one of our experienced scientific team. Turning you into an expert user able to produce the best results from your new instrument is vital to your success, as well as ours. We stay in touch with our customers over the instrument lifetime to offer scientific support or exchange of ideas via our user forum and through attendance at conferences, regular user meetings, workshops or by phone or email.

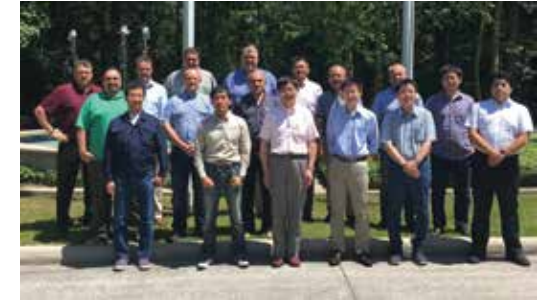

Global Service Management Team.

PROMPT TECHNICAL SUPPORT

Even the most reliable systems require support at times. With a global service presence and highly trained engineers, help is never far away. Our instruments and software are designed with remote support in mind. This helps us to help you keep your system at peak performance, minimizing both downtime and maintenance costs. Most problems can be diagnosed or fixed remotely. If parts are required, they are shipped from one of our regionally located warehouses. If a visit is required, we coordinate parts delivery with the engineer's arrival to ensure minimal downtime and efficient repair of your system.

Our engineers undergo regular training to keep their skills sharp and to ensure their readiness for new products as they arise.

TABLE OF CONTENTS

Why Choose Rigaku Oxford Diffraction?	2
Find Your Perfect Match.....	4
High-Performance Systems.....	6
The HyPix Family	8
HPC Technology for the Best Data	9
The HyPix-Bantam	10
The HyPix-6000HE	10
The HyPix-ED.....	10
The HyPix-Arc 100°	11
The HyPix-Arc 150°	11
XtaLAB mini II	12
XtaLAB Synergy-i.....	13
XtaLAB Synergy-S	14
XtaLAB Synergy-R	16
XtaLAB Synergy-DW VHF	18
Intelligent Optic Module.....	20
XtaLAB Synergy-Custom.....	22
X-ray Sample Changers.....	24
XtaLAB Synergy-ED	28
Selected Accessories and Attachments	30
CrysAlis ^{Pro}	32

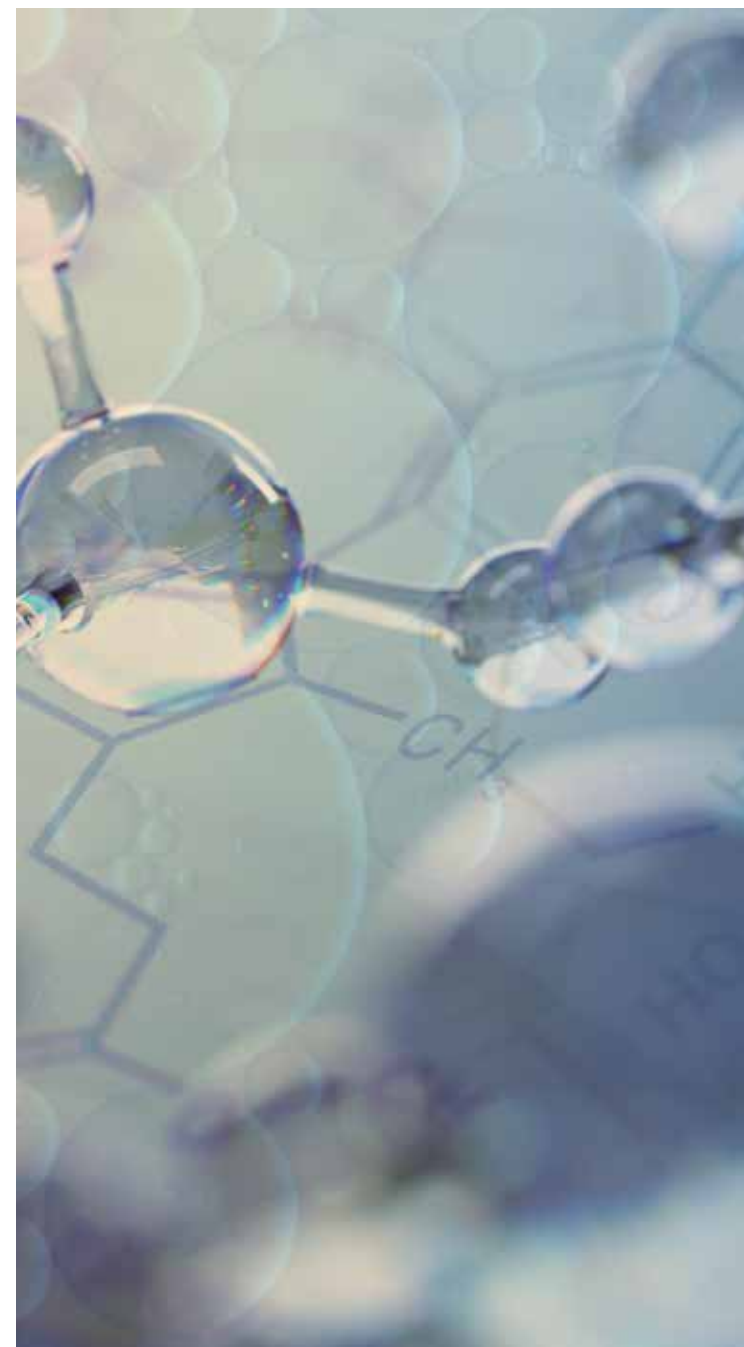

FIND YOUR PERFECT MATCH

As we strive to increase our understanding of the world, high-quality research tools are essential. We offer a range of diffractometers, from traditional sealed tube systems through microfocus sealed tubes and up to ultrahigh-flux rotating anode systems, letting you choose the right technology and performance level for your research. All Rigaku Oxford Diffraction systems come with one of our own instantaneous digital X-ray photon counting HyPix detectors as standard.



XtaLAB mini II

The perfect addition to any synthetic chemistry laboratory, the XtaLAB mini II single crystal X-ray diffractometer will enhance research productivity by offering affordable structure analysis capability without the necessity of relying on a departmental facility. With the XtaLAB mini II benchtop diffractometer, you no longer have to wait in a queue to determine your structures. Instead, your research group can rapidly analyze new compounds as they are synthesized in the lab without having to line up in the departmental core facility.



XtaLAB Synergy-i

Today's quintessential single crystal X-ray diffractometer includes a high-flux, low-maintenance microfocus sealed tube X-ray source, a high-precision 4-circle kappa goniometer and a modern X-ray detector. The XtaLAB Synergy-i is built on components that represent the latest technologies and can be upgraded from a single source to a dual source instrument in the future. The system can be equipped with Cu and/or Mo sources, allowing for a broad range of sample types to be evaluated. As with our highest-performance instruments, the XtaLAB Synergy-i is controlled by the fully integrated, user-inspired CrysAlis^{Pro} software package, so you achieve the best data possible.



XtaLAB Synergy-S

Structural scientists have made this our most popular diffractometer. It is the perfect low-maintenance system, with the possibility of one or two X-ray sources. Whether you are a MOF chemist trying to squeeze a good structure out of poor crystals or a structural biologist who wishes to screen protein crystals before shipping them to the synchrotron, the XtaLAB Synergy-S diffractometer is the perfect crystallography system if low maintenance is your primary concern.



XtaLAB Synergy-R

The XtaLAB Synergy-R is the most powerful rotating anode microfocus single crystal X-ray diffractometer available in a compact cabinet. For protein crystallographers who wish to have a powerful, well-integrated diffractometer and only need to use one part of the rotating anode, the XtaLAB Synergy-R provides the perfect combination of high-flux performance with a low-noise Hybrid Photon Counting (HPC) X-ray detector. Combining high-performance components, the XtaLAB Synergy-R allows you to collect high-quality diffraction data on even the weakest of samples. Moreover, the XtaLAB Synergy-R offers a number of design features that extend the experimental flexibility to address the most challenging samples.



XtaLAB Synergy-DW VHF

One source with two high-flux wavelengths is the foundation of the revolutionary XtaLAB Synergy-DW VHF single crystal X-ray diffractometer. It combines the increased flux of a rotating anode X-ray source with the flexibility of two different wavelengths, making it ideal for laboratories exploring a wide range of research interests. It is the perfect diffractometer for a core facility where protein crystallography and small molecule crystallography are both practiced and high throughput and small samples are a key concern. Now available with optional intelligent optics module for automated source alignment.

HIGH-PERFORMANCE SYSTEMS

For those at the forefront of research, we offer high-performance instruments, automation and instruments for complementary techniques. Our highest-performance instruments are capable of measuring down to the nanoscale, providing you with the excellent data quality you've come to expect from Rigaku Oxford Diffraction.



XtaLAB Synergy-Custom

There are times when you may need a little extra flexibility or performance from your diffractometer. For those times, we created the XtaLAB Synergy-Custom. With support for our highest-performance X-ray source, the FR-X, the XtaLAB Synergy-Custom offers you the chance to work at the forefront of crystallographic research.



XtaLAB Synergy Flow

In today's challenging research environment, maximizing your output can be essential. With the XtaLAB Synergy Flow, you can increase your output through automated operation, whether you are able to be in the laboratory or not. The unique dewar design allows samples to be added or removed at will, regardless of whether there is an experiment running or not.

With the XtaLAB Synergy Flow, 24/7 operation is a reality.



ACTOR 2

When you need the highest-performance sources, or the highest-capacity system for automation, the ACTOR 2 is the best choice.

Load 122 samples or more and let the system collect them, process them and rank them while you focus your attention elsewhere. The ACTOR 2 can be coupled to an FR-X system, giving the highest-flux automated home-lab diffractometer in the world.



XtaLAB Synergy-ED

In recent years, single-crystal electron diffraction (3DED/microED) has gained mainstream attention. The XtaLAB Synergy-ED, available since June 1, 2021, is the world's first commercially available dedicated electron diffractometer. With the ability to get structural information from samples smaller than a micron, the XtaLAB Synergy-ED allows you to study samples you simply could not before. Operated and controlled with CrysAlis^{Pro} ED, this electron diffractometer fits right into your X-ray laboratory and gives you the same familiar and intuitive user interface available on all of our diffractometers.

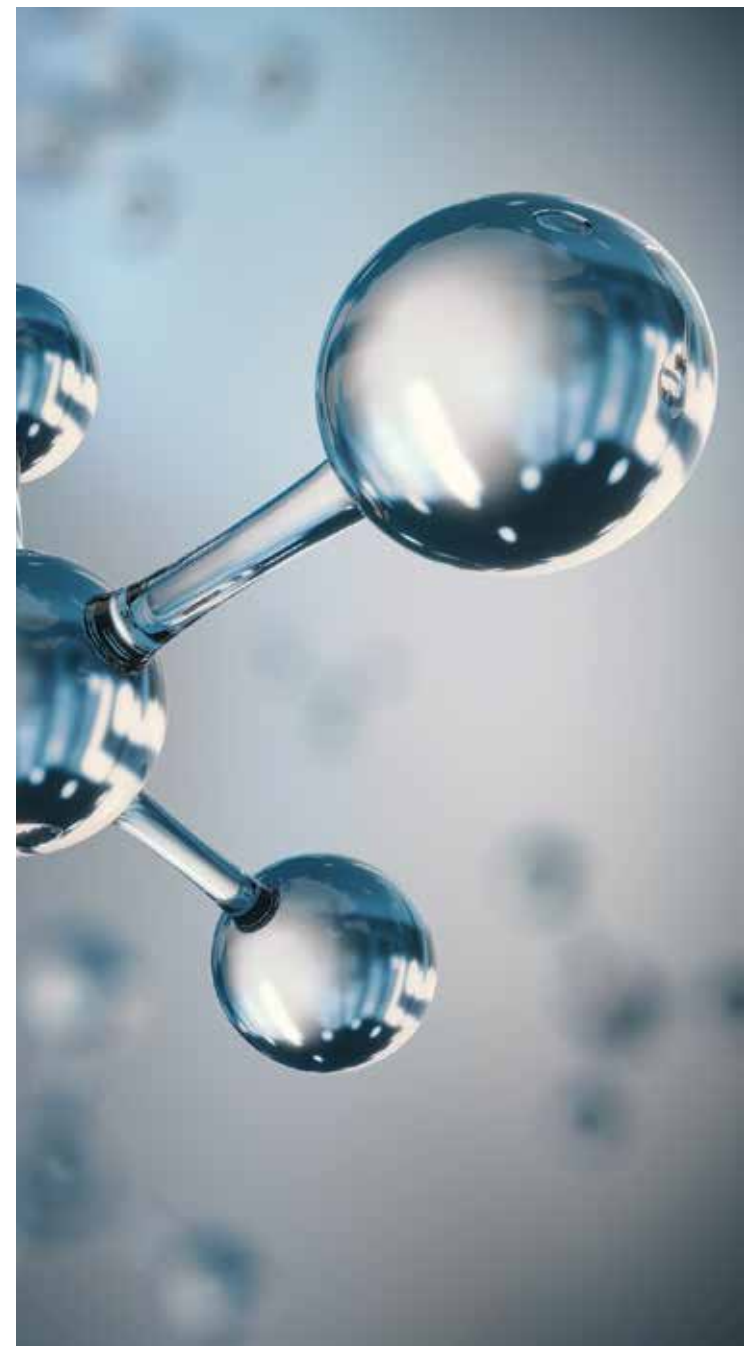

ADVANTAGES OF HPC VS CMOS/CPAD

Rigaku's own HyPix family of detectors use Hybrid Photon Counting (HPC) technology to enable direct X-ray photon detection and counting. Direct X-ray photon detection means that X-ray photons are counted instantaneously as they arrive at the detector. There is no conversion to visible light by a scintillator, so the energy of the photon can be assessed at the moment of detection. This leads to essentially noise-free images.

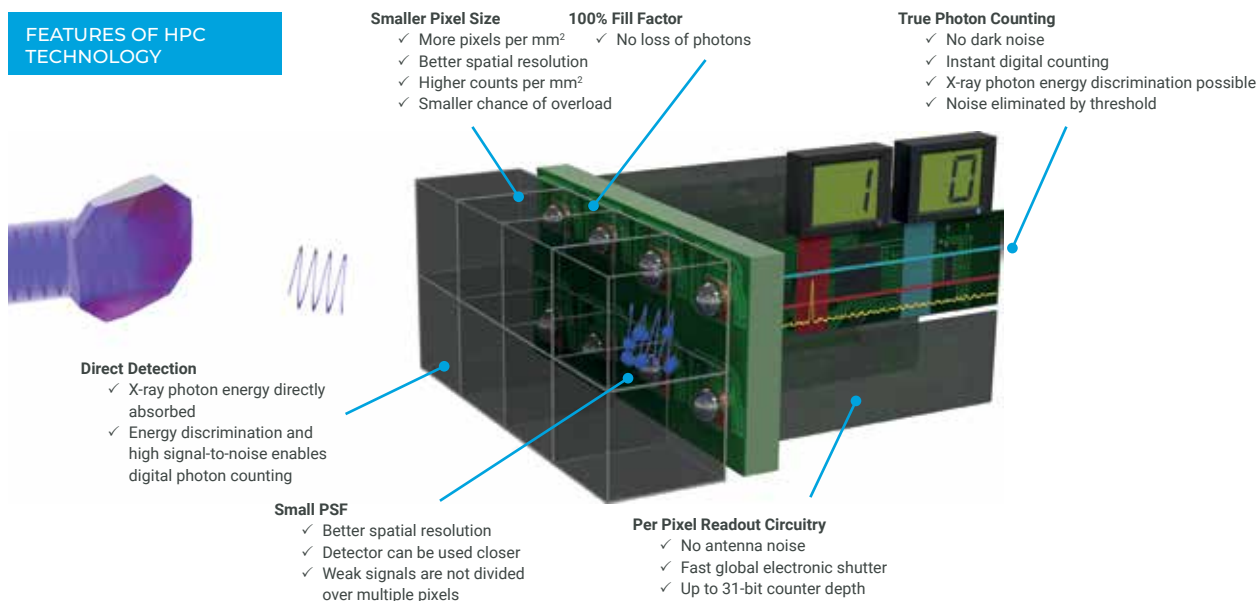
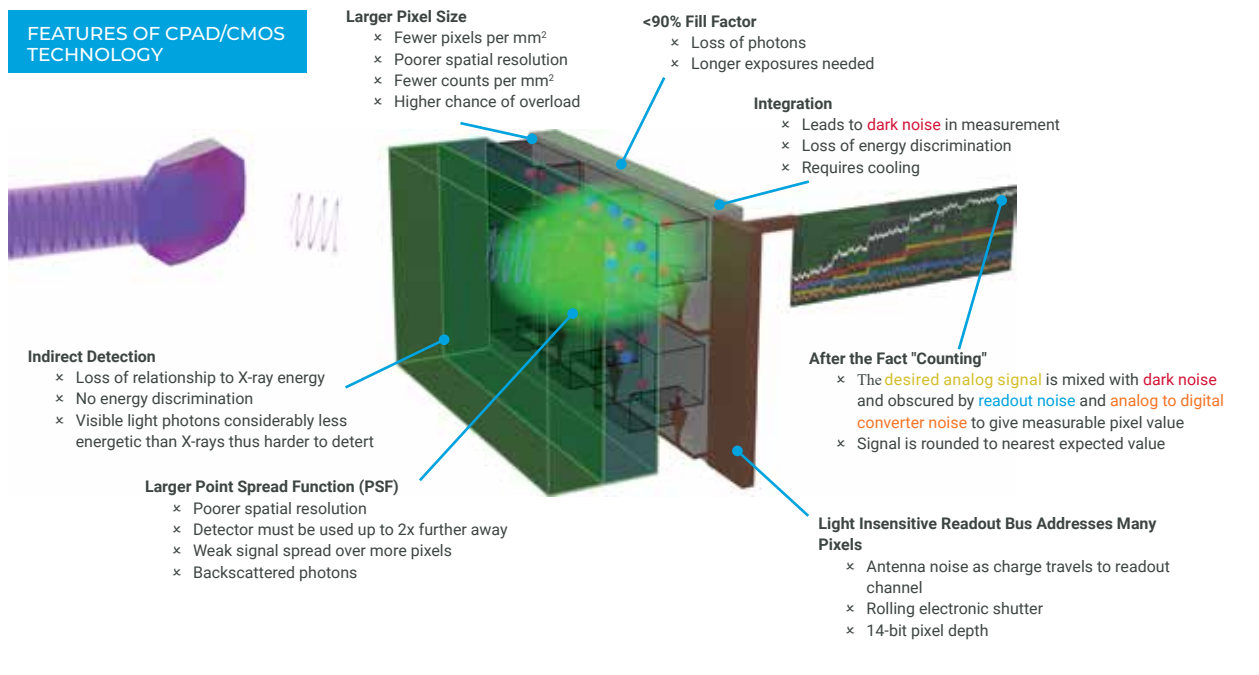

HPC TECHNOLOGY FOR THE BEST DATA

Direct detection, no scintillator:

Enables energy thresholding, instantaneous photon counting and massive dynamic range.

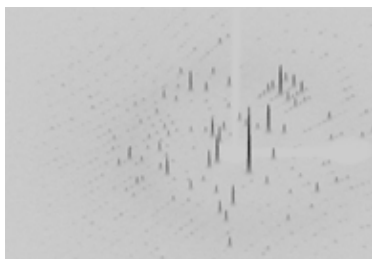

Small pixels with single pixel top

hat point spread: With no phosphor, electrons generated by an incident photons stay confined to a single pixel for the best chance at resolving twins, proteins and other long axes, even at close distances.

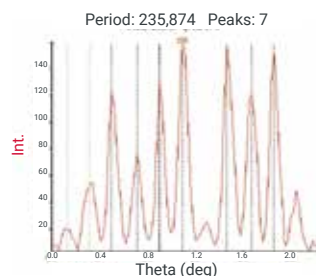
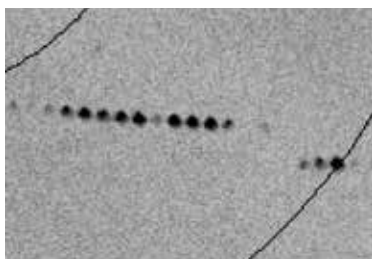

RACE technology for up to 100 Hz

and zero deadtime mode: The HyPix-6000HE, HyPix-Arc 100° and HyPix-Arc 150° contain RACE technology. Two counters per pixel allows up to 100 Hz* frame rates with negligible deadtime.

STANDARD MODE

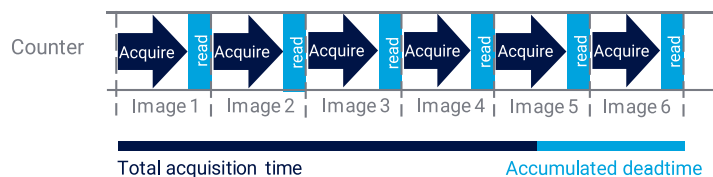

ZERO DEADTIME MODE

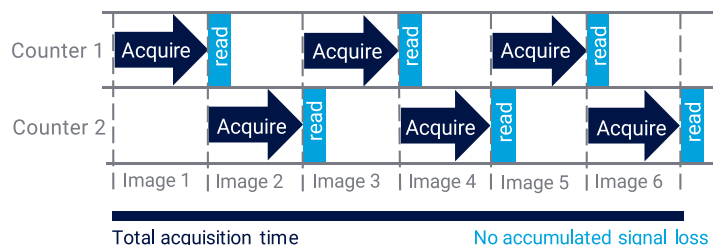

*Depending on HyPix model

THE PROOF IS IN THE MEASUREMENTS

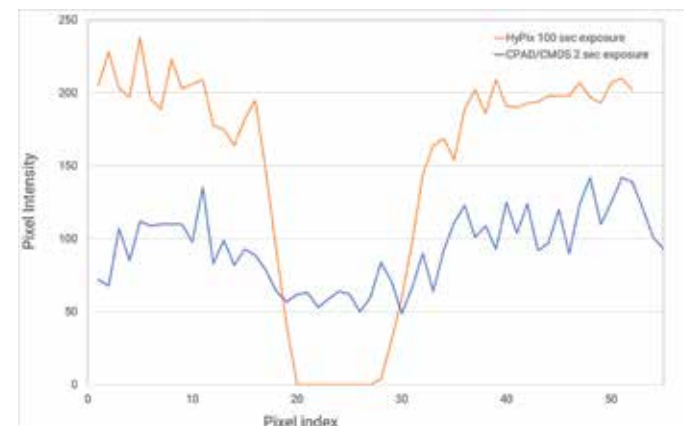

Despite 50-times longer exposure times, the noise floor (behind the beamstop) is 50-times lower for HyPix (HPC) compared to a modern CPAD/CMOS.

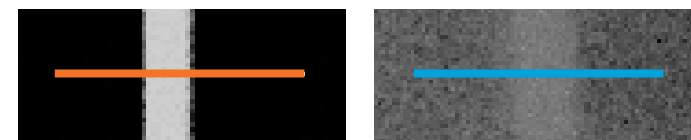

Images shown on the same intensity scale, HyPix 100 second exposure shows zero counts across the beamstop in some places as expected. Other areas show only one or two counts due to air scatter. CPAD/CMOS shows a minimum of 50 counts despite only a 2 second exposure.

FLAT HyPix DETECTORS

THE HYPIX-BANTAM

The HyPix-Bantam punches above its weight, offering cutting-edge HPC features in an affordable package. It offers direct X-ray photon detection and photon counting for the best data quality, along with a small pixel size for excellent spatial resolution even at short sample-to-detector distances. With no readout noise, this detector gives you the best chance of recording signal information from your sample without subsequently swamping the signals with detector noise.

THE HYPIX-6000HE

The HyPix-6000HE detector doubles the active area of the HyPix-Bantam while also adding more features. Pixels incorporate dual counters, enabling several modes of operation.

- Rapid Alternating Counter Electronics (RACE) technology enables the 100 Hz zero deadtime mode, ensuring that no pixel is blind for more than a few nanoseconds during exposure to X-rays.
- The high dynamic range mode combines the counters to offer a massive 31-bit counter depth.
- Dual thresholding offers differential modes and selective signal suppression.

The 100 Hz frame rate allows for data fine slicing even at the fastest goniometer speeds. Direct detection of X-ray photons, as with all HyPix family detectors, gives the best chance at detecting and counting X-ray photons with virtually no noise and ultrafast operation.

THE HYPIX-ED

For electron diffraction, we have optimized the technology in the HyPix family of detectors for the electron diffraction experiment.

The HyPix-ED is the detector inside our XtaLAB Synergy-ED electron diffractometer, providing excellent data quality in the electron diffraction research field. Though detecting electrons rather than photons, the same benefits apply: zero dark noise, zero readout noise, and instantaneous event-driven counting. The HyPix-ED offers 100 Hz operation with its zero dead time mode. High sensitivity for electrons means that the HyPix-ED can measure weak diffraction and enables the highest-quality data possible from your electron diffraction experiments with short exposure times so you can keep beam damage to a minimum.



CURVED HyPix DETECTORS



THE HyPix-Arc 100°

In the goal of offering more efficient detectors, the traditional solution has been to chase larger and larger area. To achieve this, either cheaper fabrication technologies must be used or the cost must increase. Additionally, after a point, larger areas don't help as much. The HyPix-Arc detectors use their area more intelligently by wrapping the detector around the sample to improve parallax, improve detector coverage and provide better data quality.

The HyPix-Arc 100° improves upon the HyPix-6000HE, with a larger accessible theta range for faster data collections. This detector gives superior data quality and fast data collection times, and comes hermetically sealed and water-cooled to ensure stable, high performance without disrupting the sensitive sample environment with exhausted heat and air turbulence.

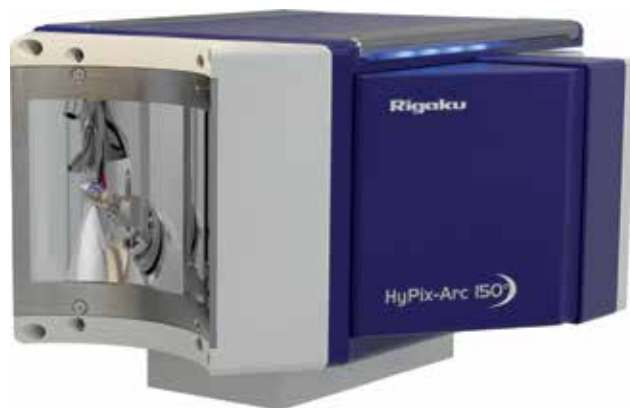

THE HyPix-Arc 150°

With the HyPix-Arc 150°, less is more. Arranging its sensors on a curve allows for theta coverage exceeding the largest detectors while still offering the highest-performing detection technology. With the highest static 2θ range available in the home lab, the HyPix-Arc 150° offers you the best approach to data collection, measuring reflections all the way up to and beyond the IUCr recommended minimum limit for common home lab wavelengths.

The curved geometry simplifies scaling for the best data quality, accelerates high-resolution data collection and reduces distortion of reflection profiles compared to large flat detectors. Based on HPC technology, all of the benefits of direct, instantaneous X-ray photon counting are present. A single-pixel top-hat shaped point spread function means the detector can be used at much closer crystal-to-detector distances than large scintillator-based detectors while achieving the same spatial resolution. Energy discrimination, fast frame rates and no dark or readout noise make the HyPix-Arc 150° a truly amazing detector and a valuable addition to your research laboratory.

XtaLAB mini II

SMALL BUT MIGHTY

The XtaLAB mini II benchtop X-ray crystallography system is designed to produce publication-quality crystal structures. The simple design and small footprint make it perfect as a quick access system in a synthetic lab, teaching crystallography on a live instrument or simply when lab space is at a premium.

Equipped with a Mo sealed tube source running at 600 W, SHINE focusing optics, and a HPC detector with no readout or dark noise, the XtaLAB mini II offers research-level performance in a compact package.



THE XtaLAB mini II DIFFRACTOMETER

Features

- HPC detector with 100 μm pixels and no readout or dark noise
- Simple design with a small footprint
- Low-power sealed tube molybdenum X-ray source with focusing optics
- Compatible with a Cryostream 1000 and Smartstream low temperature attachments
- Compact, fail-safe radiation enclosure

Unique Benefits of the XtaLAB mini II

Benchtop diffractometer providing publication-quality results.

User-friendly and semi-automated.

Robust enough for students to operate in a teaching environment.

Latest low-noise HPC detector technology.

Researcher and student friendly, comprehensive CrysAlis^{Pro} software.

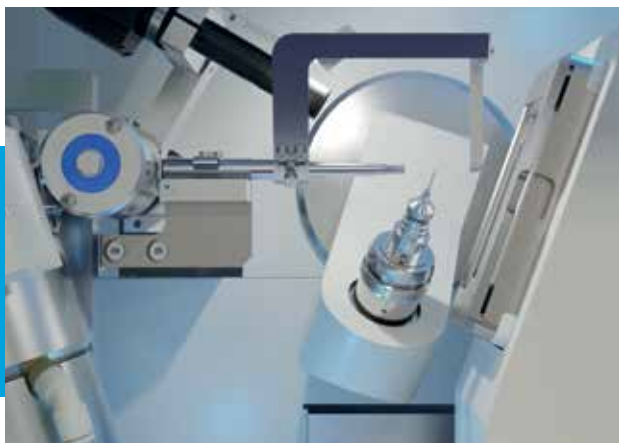

The XtaLAB mini II has just three moving parts: the shutter, the phi and the omega axes of the goniometer. The simple, compact design and 600 W X-ray source means minimal maintenance and no special infrastructure requirements, so the XtaLAB mini II just keeps on providing data, sample after sample.

XtaLAB Synergy-i

A CUTTING-EDGE DIFFRACTOMETER FOR ALL YOUR CRYSTALLOGRAPHY NEEDS

Whether you select a dual or single source microfocus configuration, the XtaLAB Synergy-i provides the latest technology, from the sources to the detector.

- The latest HPC detector for instantaneous, digital photon counting
- Both dual and single source configurations with microfocus technology as standard
- Kappa goniometer ensures publication standards are met, even for low symmetry samples



Unique Benefits of the XtaLAB Synergy-i

The scintillator-free HPC detector has been designed by Rigaku to ensure cutting-edge performance with instantaneous digital X-ray photon counting technology for unparalleled sensitivity.

The microfocus PhotonJet-i sources (Cu/Mo), available in dual or single source configurations, have low power consumption, yet provide high flux in order to study a variety of sample types.

The 4-circle kappa goniometer ensures that the most efficient data coverage is achieved even for the lowest symmetry samples whether Cu or Mo radiation is used.

Latest low-noise HPC detector technology.

Researcher and student friendly, comprehensive CrysAlis^{Pro} software.

Sample Type	Mo	Cu
Purely inorganic	☑	✓
Organometallic	☑	✓
Organic	✓	☑
Absolute structure (organics)		✓
Twinning	✓	☑
Charge density	✓	
Incommensurates	☑	✓
Highly absorbing	☑	✓

○ Preferred radiation choice

Additional Features

- The XtaLAB Synergy-i is compatible with most low temperature devices, including the Smartstream, Cryostream 700, 800, and 1000 series, and the Cobra.
- Convert your XtaLAB Synergy-i from a single source to a dual source instrument at a later date, along with other upgrade options.



XtaLAB Synergy-S

FAST, ACCURATE, INTELLIGENT

Designed for Data Quality and Speed

The common goal of any single crystal experiment is to efficiently and accurately measure reciprocal space data.

This is true whether you are determining the structure of a novel chemical compound, screening protein crystals before a synchrotron trip or measuring highly redundant, high-resolution data for a charge density study. In all cases, the quality of the data generated by your diffractometer, as well as the speed and ease by which you can measure the data, is paramount to your productivity.

The XtaLAB Synergy-S diffractometer meets and exceeds these needs. High-performance components and user-inspired software come together to produce accurate datasets, fast and in an intelligent fashion.

The XtaLAB Synergy-S comes as single or dual source with PhotonJet-S X-ray sources (Mo, Cu, or Ag), a high-speed kappa goniometer, an HPC detector, and an ergonomically designed radiation enclosure.

Choose one of Rigaku's own HyPix detectors, including the new HyPix-Arc 150° for extreme angular coverage and photon counting. Selected DECTRIS® HPC detectors, such as the Eiger models, are optionally available.

Unique Benefits of the XtaLAB Synergy-S

Extremely powerful and tightly stabilized X-ray source for best, consistent performance.

Highest-throughput sealed tube diffractometer available.

Class-leading results in all applications.

Extremely low noise photon counting detector.

Researcher and student friendly, comprehensive CrysAlis^{Pro} software licenses.

Features

- PhotonJet-S X-ray sources use high-reliability X-ray tubes with Rigaku designed multilayer optics.
- A fast goniometer allows data collection scan speeds of up to 10°/sec.
- A choice of Rigaku HyPix detectors with true photon counting and fast frame rates.
- AutoChem and “What is This?” are included with every XtaLAB Synergy-S diffractometer. Automatically solve structures and find out what your sample is in a few seconds, before committing to a full dataset.
- Highly stable closed-circuit water-cooled tubes produce the most consistent X-ray output with no external water or chillers.
- Small molecule or protein capable with dedicated workflows.
- Highest level of safety, with multiply redundant electromechanical safety circuits.
- Online diagnostics and troubleshooting to diagnose and fix almost all problems without a site visit.



PhotonJet-S

The XtaLAB Synergy-S is defined by its new PhotonJet-S X-ray source. With a new microfocus sealed tube designed for Rigaku and engineered specifically for long lifetime single crystal research, the PhotonJet-S incorporates a new mirror design from Rigaku Innovative Technologies and new alignment hardware.

The PhotonJet-S sources provide almost double the flux for all three target types (Mo, Cu, Ag) compared to the previous generation.

For the best data quality, it is important to ensure any source provides highly reproducible flux, frame after frame. As tube temperature changes, so does the X-ray flux reaching your sample. Controlling the temperature of our sources using closed-circuit water cooling offers the best solution for consistency, high performance and reliability in a completely standalone package.

BEAM CONDITIONING

Where overlapping peaks are a concern—e.g. large unit cells, proteins, twinned or incommensurate samples—high beam divergence is undesirable. On PhotonJet sources, a software-controlled, motorized variable beam slit is available as an option to alter divergence to adapt the source to your sample's requirements. For those samples where intensity matters most, the slit can be fully opened, giving the highest flux. For those where peak sharpness and overlap are factors, the beam can be limited to a divergence anywhere between 1 to 10 mrad.

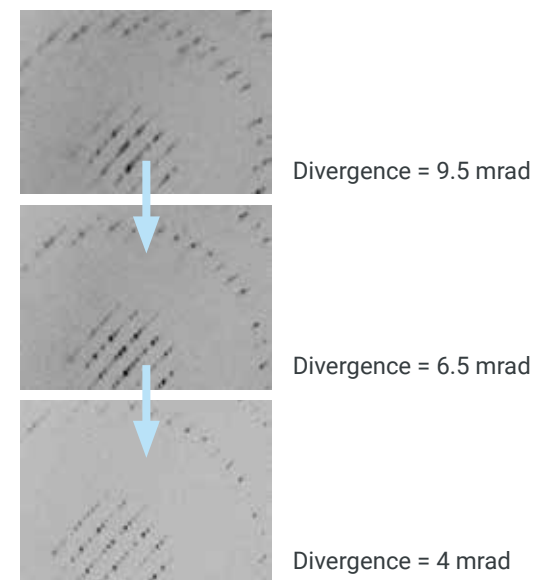

The protein catalase has a 229 Å axis that requires reduction of the divergence angle in order to properly resolve the reflections. These images were obtained at a crystal-to-detector distance of 70 mm.

XtaLAB Synergy-R

RAW POWER, REFINED

Compact Microfocus Rotating Anode Based System

A unique combination of cutting-edge technologies allows the XtaLAB Synergy-R to claim the title of “World’s Fastest Diffractometer.”

Greatly reduce data collection time or open the doors to research targets you never dreamed you could study in your own lab. Class-leading brightness, high reliability built into every component and ease of use—for difficult samples, the XtaLAB Synergy-R is the smart choice.

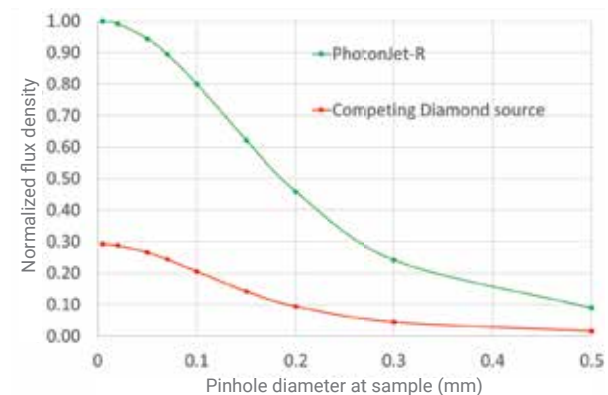

Unique Benefits of the XtaLAB Synergy-R

A bright source, a fast goniometer, and an extremely low-noise, photon-counting detector means that the XtaLAB Synergy-R system is well-suited to accommodate almost anything you can throw at it.

The PhotonJet-R microfocus rotating anode has the lowest maintenance of any modern rotating anode or metal jet generator.

The XtaLAB Synergy cabinet provides electronically controlled lighting and plenty of room for tools and a microscope.

The HyPix-6000HE detector directly detects X-ray photons and delivers a single pixel top hat point spread function to minimize noise.

Researcher and student friendly, comprehensive CrysAlis^{Pro} software licenses.

Features

- The XtaLAB Synergy-R has significantly more flux than current microfocus sealed tube sources without resorting to ultrahigh divergence.
- An innovative continuously variable slit system is available so you can tune the source divergence to your sample.
- Faster motor speeds of the goniometer have been optimized to take advantage of the high-flux X-ray source.
- Telescopic 2 θ arm can access full theta range but also allows long crystal-to-detector distances for samples that need it.
- The data quality is exceptional due to the sophisticated HPC technology employed by Rigaku detectors. No readout noise, no dark noise, and instantaneous, digital, single photon counting give the best data quality possible.

PhotonJet-R

The PhotonJet-R comes from the same pedigree as the MicroMax™-007 HF, of which there are over 1000 units in use around the world.

The PhotonJet-R X-ray source applies the lessons learned over the development and lifetime of the MicroMax-007 rotating anode to produce a new generation, high-performance rotating anode source.

With the source mounted directly onto the goniometer, the XtaLAB Synergy-R provides a stable and robust solution that ensures consistently high performance. Confocal optics designed by Rigaku Innovative Technologies offer high brilliance and an optional continuously variable slit assembly gives high brilliance or low divergence as needed to cater to any sample.

PROVEN RELIABILITY

The PhotonJet-R source was designed with reliability in mind. Clever Rigaku engineering makes filament changes easy, like swapping a printer cartridge, with no need to realign the source each time.

Scheduled maintenance involves one annual visit from a Rigaku engineer, as with all XtaLAB Synergy diffractometers, and typically takes 1-2 days. With the anode exchange program, you get the benefit of rotating anode power with the convenience of sealed tubes.

WHY CHOOSE A ROTATING ANODE?

Rotating anodes make your life easier. Don't spend your time struggling with poor quality datasets which can be improved simply by collecting with a higher-intensity source. Don't miss out on an important result because you can't get publishable data because your source is too weak. Measure what you couldn't before.

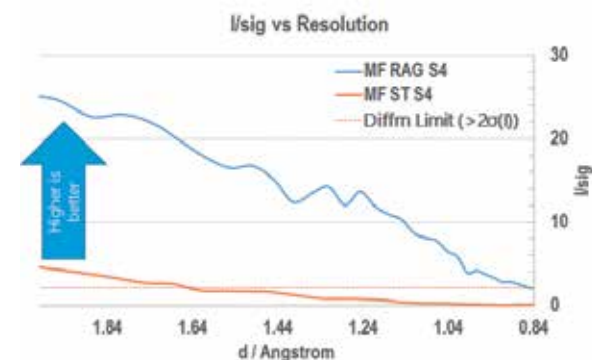

The diffraction limit of a 10 μm small organic crystal was too low to meet publication standards (red dotted line) when collected with a XtaLAB Synergy diffractometer (orange line). When the same crystal is collected with a PhotonJet-R source (blue), publication quality can be reached.

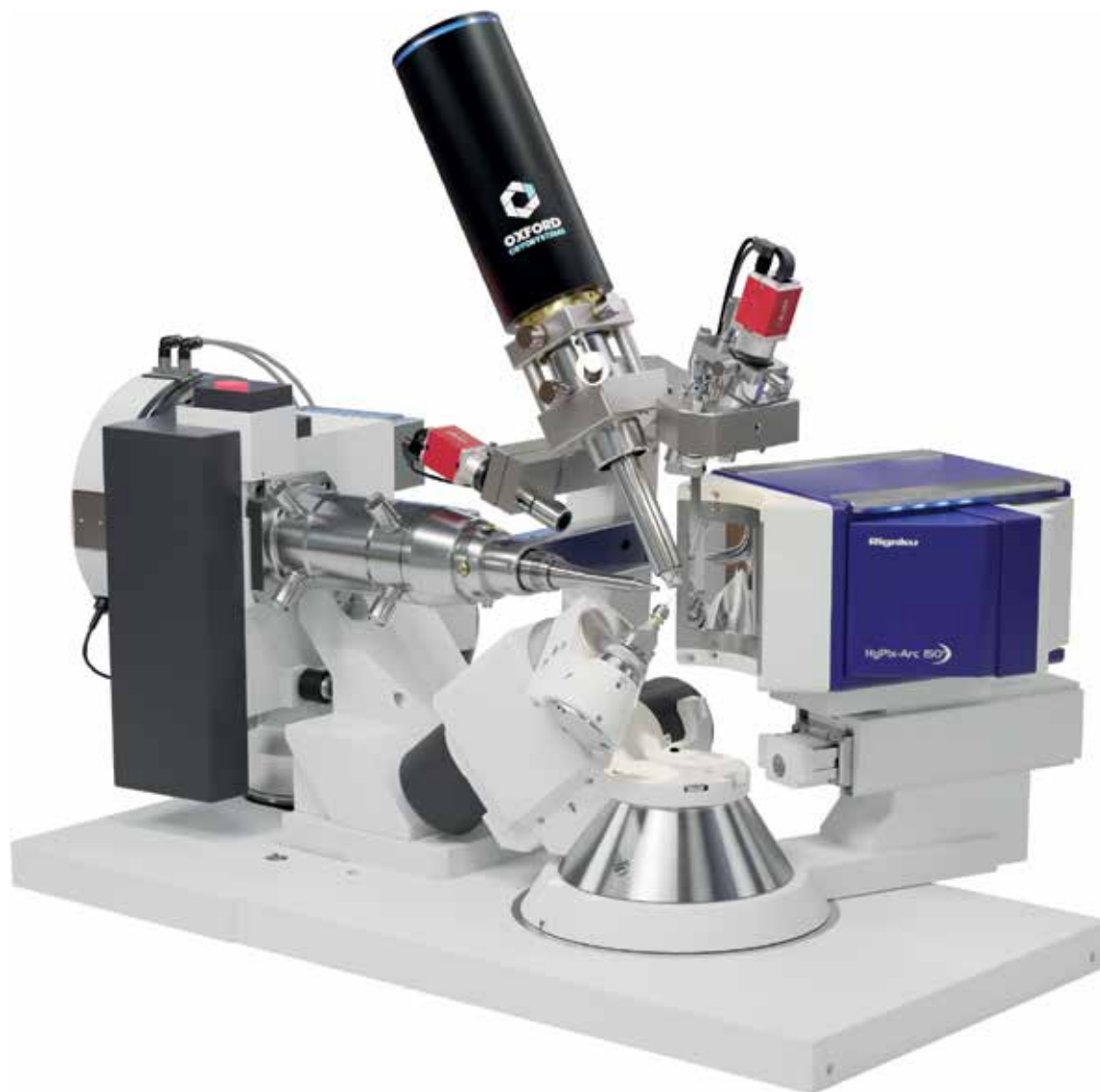

XtaLAB Synergy-DW VHF

INTENSELY VERSATILE

One Anode, Two Wavelengths

Investing in a rotating anode often leaves one more important decision to make. Which wavelength is right for me?

The XtaLAB Synergy-DW VHF lets you have your cake and eat it too, offering rotating anode flux density with not one, but two wavelengths.

In a chemical crystallography X-ray laboratory, a wide range of samples often need to be studied, from the weakly diffracting to the strongly absorbing. Having the choice of two wavelengths gives you the flexibility to address the vast majority of sample types without needing two diffractometers.

The XtaLAB Synergy-DW VHF offers even more performance than its predecessor, with more than twice the flux density available.

Unique Benefits of the XtaLAB Synergy-DW VHF

Unique dual wavelength diffractometer.

Exceptional data for charge density studies to protein crystallography and everything in between.

Significantly more flux than any microfocus sealed tube source.

HyPix detectors directly detect X-ray photons and deliver a single pixel top hat point spread function to minimize noise.

Researcher and student friendly, comprehensive CrysAlis^{Pro} software licenses.

PRECISION ENGINEERING

The XtaLAB Synergy-DW VHF represents a remarkable technological achievement. Rigaku has in-house expertise in design and manufacture of each component needed to realize a highly precise, high-performance instrument of this class.

- High-performance multilayer confocal X-ray optics capture and focus the X-rays onto the target.
- A specially designed, motorized, dual-optic chamber moves the chosen optic into place with high accuracy and precision and no need to realign.
- A carefully designed pneumatic system moves the target track under the electron beam without breaking vacuum.
- Switching wavelength takes only **five minutes**.

APPLICATIONS

Whether your need is high throughput or you just need to enhance weaker diffraction, the XtaLAB Synergy-DW VHF is able to provide. The unique single source form factor offers you the possibility of using two wavelengths from one collimator without another source restricting detector access on one side. If your research involves high-resolution data collection (e.g., charge density), this enhances your ability to collect complete data quickly without having to compromise with a single source instrument.

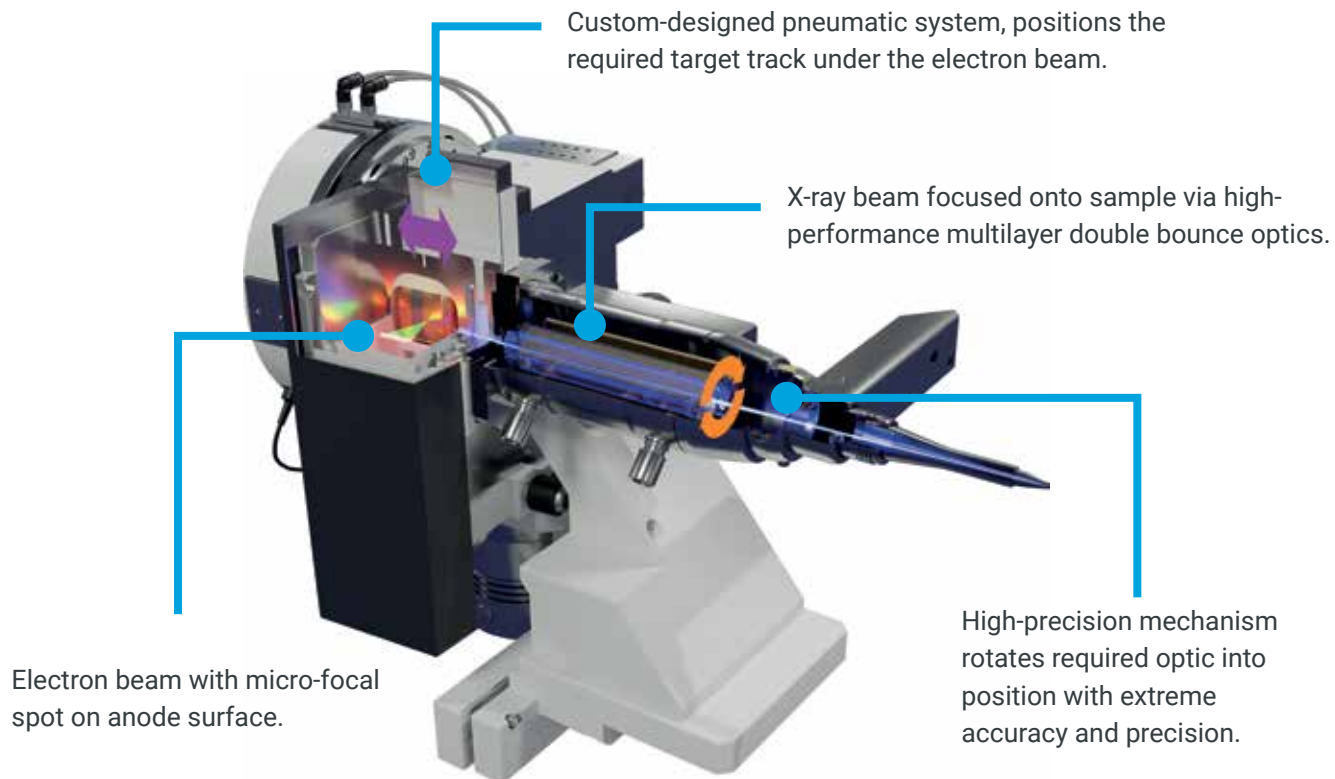

VERSATILITY

A choice of two wavelengths lets you cover a wide range of samples and techniques, from proteins to minerals, charge density to absolute configuration.

DETECTORS

The XtaLAB Synergy-DW VHF can be purchased with the HyPix-6000HE, HyPix-Arc 100° or HyPix-Arc 150° detectors. Rapid Alternating Counter Electronics (RACE) technology allows pixel counters to be switched in just a few nanoseconds,

enabling a zero dead time mode with a 100 Hz frame rate. Both RACE technology and fine slicing ensure both strong and weak data can be measured accurately with the higher flux of rotating anode sources.

With more than twice the flux density over its predecessor, the XtaLAB Synergy-DW VHF offers even more versatility in the home lab. The extra brightness allows even more challenging samples to be studied, whether they are smaller or have poorer crystallinity.



Intelligent Optic Module

EFFORTLESS INTENSITY

Automatic beam alignment for consistent performance

The XtaLAB Synergy-DW VHF can now be equipped with our new Intelligent Optic Module (IOM) for fully motorized automatic beam alignment. With encoders on every axis, the IOM puts the beam exactly where you need it with high reproducibility, perfect for the smaller samples commonly studied today. The IOM also lets you achieve maximum intensity from your source by automatically maximizing the intensity so you can achieve peak performance at all times.

Unique Benefits of the Intelligent Optic Module
Fully automatic optic alignment for reproducible, safe and simple alignment
Peak performance at all times
Remote source optimization from the next room or the next continent
Align your source with the safety enclosure closed and interlocked

PEAK PERFORMANCE

With automatic alignment, your source can maintain peak performance all the time. Perfect alignment can be achieved within a few minutes to keep your system ready for the smallest and most challenging samples.

PRECISION ENGINEERING

Reproducibility

The IOM device has been designed with encoders on each motor to ensure it knows its exact position. When aligning the beam, this enables the best position to be automatically found and remembered so optimal alignment can be easily recovered.

Safety

Manual alignment of X-ray sources often requires direct access to knobs and screws inside the radiation safety enclosure. This represents a risk of exposure to X-ray radiation and thus is often left to service engineers to perform.

The IOM device allows fully remote alignment of the X-ray optic while the X-ray safety enclosure is safely interlocked.

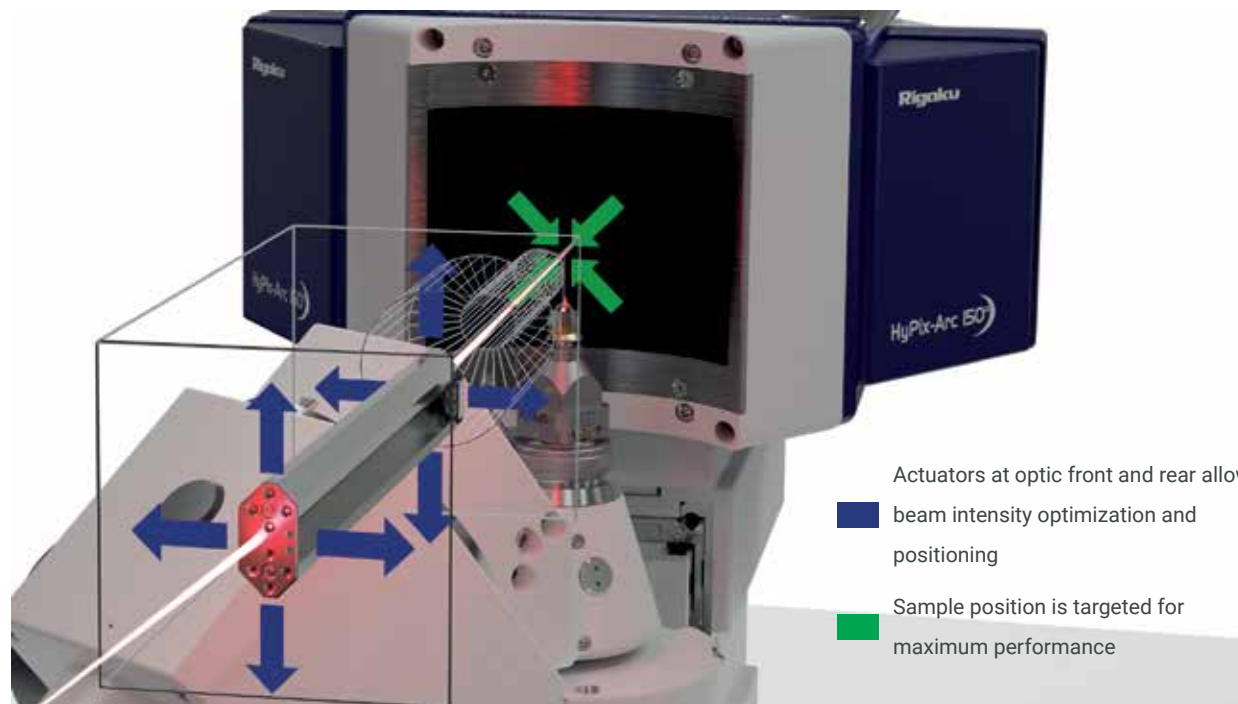

Simplicity

X-ray source alignment has never been easier with the IOM device attached to your source. The X-ray optic can be aligned either using manual point and click to point the beam at the sample or automatic alignment for maximum intensity in just a few minutes.

More Independence

The IOM gives unprecedented control over the optic position, all controlled via a software interface. This means that service engineers no longer need to be present on-site to achieve full optic alignment. Either use our automatic routine or adjust the alignment yourself with an easy-to-use, intuitive software interface.

Still not confident? Our service engineers can step in and perform alignment and source diagnostics over the internet, minimising your service costs.

XtaLAB Synergy-Custom

THE ULTIMATE IN FLEXIBILITY

For those occasions where more flexibility or power is needed, we developed the XtaLAB Synergy-Custom.

This system features the same core components of our other X-ray diffractometers but built onto a larger more flexible platform. That means the same highly reliable goniometer, high-sensitivity HPC detectors and control software with added mojo.

If you have a novel application that requires more space around the goniometer, you want to maximize your investment with a dual port system or you want to leverage our highest performance FR-X rotating anode source, the XtaLAB Synergy-Custom is the instrument for you.



Unique Benefits of the XtaLAB Synergy-Custom

Unmatched performance in the home lab with the FR-X rotating anode generator.

Dual wavelength options available.

Support for the widest range of hardware and attachments of all of our instruments.

Controlled by CrysAlis^{Pro} for an easy, intuitive experience.

Flexibility to adapt the instrument to your research needs.

MAXIMIZE YOUR INVESTMENT

Investing the time and effort into the acquisition of a new instrument should be as rewarding as possible. Rigaku rotating anodes offer dual port configuration which allows a single source to serve two endstations.

Configuration options

A dual port system can help you increase your productivity with a dual diffractometer setup, or extend your capabilities with two different configurations on each side of the source. You can even add a BioSAXS-2000^{nano} to add an entirely new technique to your lab. There is no need to decide on a single or dual port system right away. XtaLAB Synergy-Custom rotating anodes are dual port ready, meaning we can upgrade your single port system to a dual port system at a later date.



THE HIGHEST-FLUX X-RAY SOURCE

The Rigaku FR-X generates more photons than any other home laboratory X-ray source available today, providing brightness exceeding some second generation bending magnet synchrotron beamlines, with around 25 times the flux density of a microfocus sealed tube system. If your research demands raw power either for throughput, poor crystallinity or you are studying exceptionally small crystals, the FR-X might be the source for you.

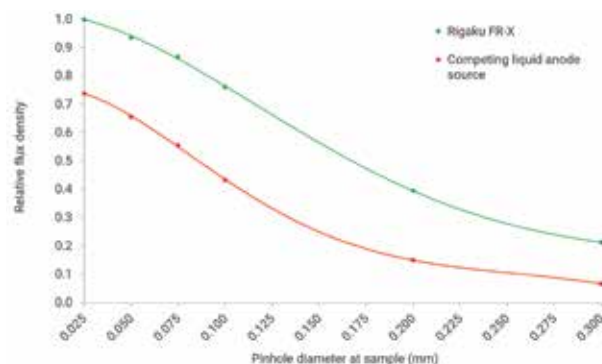

FR-X X-ray Generator



MicroMax-007 HF

FLEXIBILITY

Dual wavelength

The XtaLAB Synergy-Custom can offer dual wavelength versions so you can be sure you always have the right tool for the job at hand. With a dual wavelength configuration, there is no need to purchase and install two large instruments side-by-side to satisfy the research needs of your lab.

More space

Installed onto a large optical table, the XtaLAB Synergy-Custom's flexibility is tremendous. For those researchers who are looking to establish new techniques with new equipment or integrate something a bit bigger than the typical X-ray diffraction attachments, we can probably meet your needs with the XtaLAB Synergy-Custom so you can meet your goals.



XtaLAB Synergy Flow

INTELLIGENT AUTOMATION

Time is your most valuable commodity. The XtaLAB Synergy Flow is designed to give you back as much of your time as possible. Building on lessons learned with our extremely popular ACTOR™ sample changer, the XtaLAB Synergy Flow incorporates many innovations and enhancements to provide a reliable, safe and convenient sample-changing robot.

Whether you are screening protein samples or running a high-throughput chemistry instrument, the XtaLAB Synergy Flow has features that are sure to please the most demanding of crystallographers.

Unique Benefits of the XtaLAB Synergy Flow

Unattended operation.

Exchange samples without interrupting in-progress experiments.

Sample tracking via automatic barcode reader.

Co-mounted on goniometer base for safe, reliable sample transport.

CrysAlis^{Pro} for control, queuing and ranking of samples.

DESIGNED FOR DEMANDING WORKFLOWS

The XtaLAB Synergy Flow is comprised of a 6-axis robotic sample changer and sample storage dewar with a microdosing LN2 system.

Coupled with the data processing automation features already present in CrysAlis^{Pro}, the XtaLAB Synergy Flow adds automatic sample changing, allowing extreme productivity while you aren't even present.

You can exchange samples at any time, without interrupting data collections in progress via the cleverly designed dewar drawer. This allows the sample storage dewar to be accessed from outside the cabinet without compromising X-ray safety and enables continuous operation as long as you still have samples to run.

While the sample dewar is stowed, a microdosing LN2 delivery system makes sure the LN2 level inside is kept constant to protect your samples.

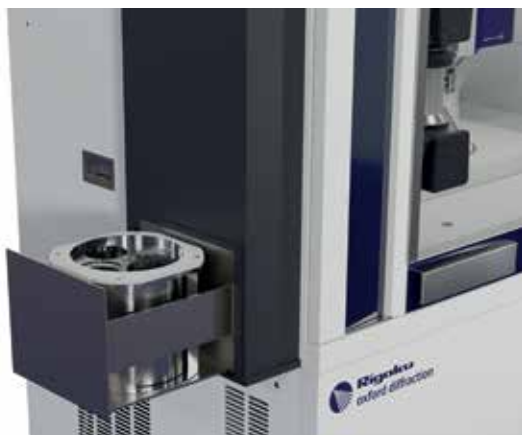

FIRST CLASS SOFTWARE

A new module called CAP Robotics has been added to CrysAlis^{Pro} to enable interaction with the Flow robot. This module features everything you need to use the XtaLAB Synergy Flow effectively from manual triggering operations or automatically queuing up the samples you'd like to collect data for, all in an easy intuitive way.

Prepare

Pucks are visually represented in software making it easy to work with your pucks, enter sample information, or import it from csv files.



Collect

Data collections can be queued up quickly and easily according to your needs, whether multiple dataset per sample are needed or not.

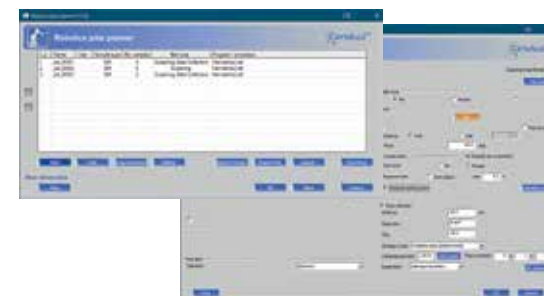

Analyze

After your queue has finished, the results viewer makes at-a-glance analysis easy and with the sample ranking feature, automatically scored



CONFIGURATIONS

To make sure you can get the automation you want with the performance you need, the XtaLAB Synergy Flow comes with options for both the source and detector.

Sources available: PhotonJet-S, PhotonJet-R, PhotonJet-DW

Detectors available: HyPix-6000HE, HyPix-Arc 100°, HyPix-Arc 150°

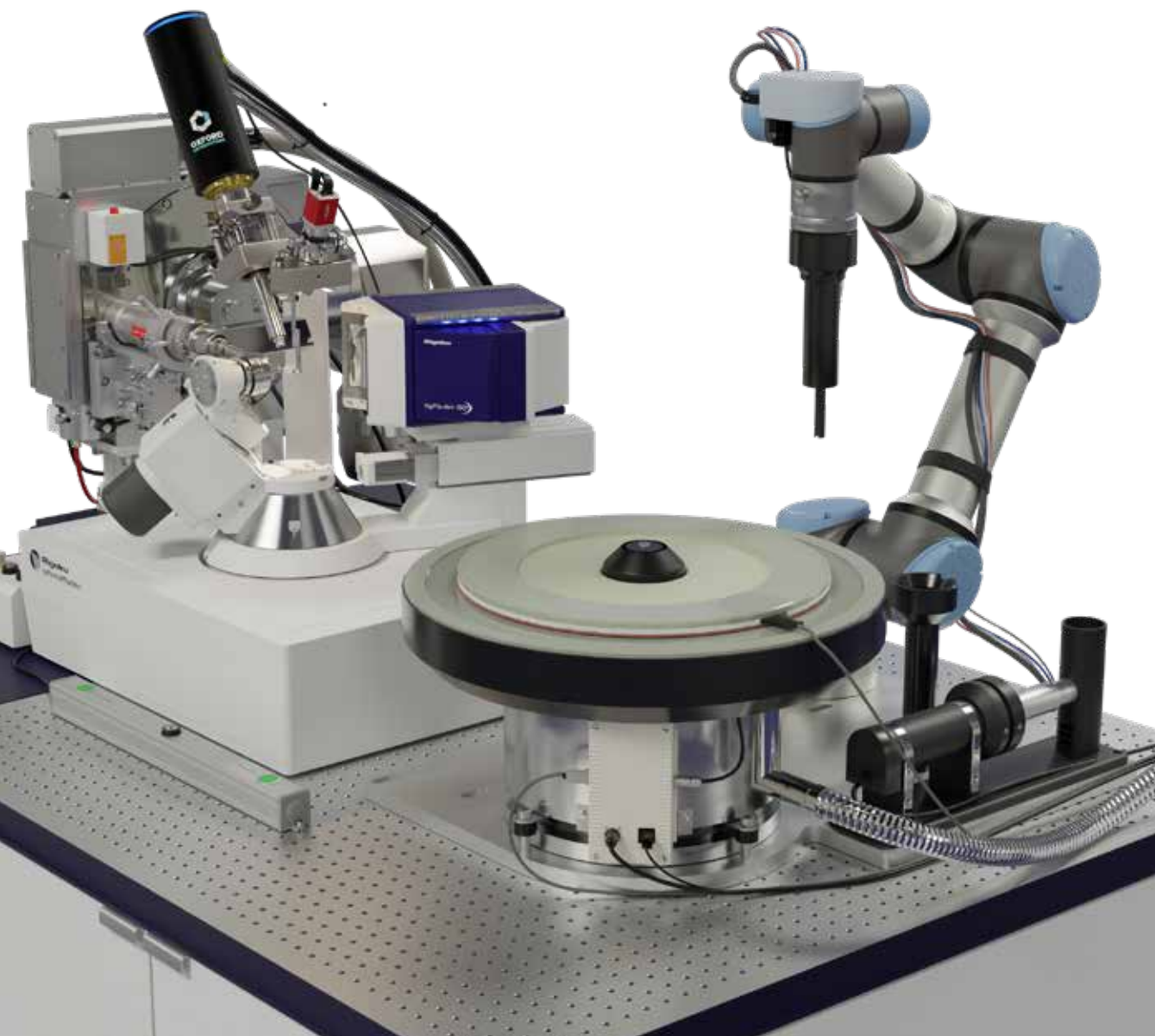

ACTOR 2

HIGH-PERFORMANCE AUTOMATION

The ACTOR system has been installed more than 70 times around the world. Consequently, it is a mature, reliable and stable system trusted by many with their most precious samples.

Now the ACTOR system has been upgraded with a new robotic arm to bring it up to date with the same technology used in the XtaLAB Synergy Flow. The ACTOR 2 system is suitable for automation in applications where a compact diffractometer cabinet doesn't offer enough space, or the highest-performance X-ray sources are needed.

Unique Benefits of the ACTOR 2

Unattended operation.

High dewar capacity for extended operation

Sample tracking via automatic barcode reader.

Co-mounted on goniometer base for safe, reliable sample transport.

CrysAlis^{Pro} for control, queuing and ranking of samples.

DESIGNED FOR MAXIMUM THROUGHPUT

The ACTOR 2 system, not being constrained by a compact enclosure, has a high-capacity dewar, giving it an extended operation time when screening and collecting data on your samples.

The ACTOR 2 uses the UR5 robotic arm from universal robotics, which has more reach, giving more flexibility in your diffractometer layout and the possibility to support multiple dewars for even higher capacity.

The ACTOR 2 retains backwards compatibility with the original ACTOR ecosystem, giving you a seamless pathway to replace your aging hardware without retooling your whole lab.



HIGHLY REFINED HARDWARE

The ACTOR system has been designed for intensive use and has been refined many times since it was first introduced in 2002.

End effector

The end effector has been refined over several generations to minimize icing and securely transfer samples.

Ice-free dewar design

The ACTOR dewar has a high sample capacity of up to 112 samples per dewar with up to 3 dewars possible. A sliding lid minimizes water ingress to prevent icing over extended automated run times.

Pin detection

The ACTOR system includes multiple pin detection methods to ensure system integrity.



VERSATILE SOFTWARE

Abstracted hardware

Whether using a XtaLAB Synergy Flow or ACTOR 2, CrysAlis^{Pro} and the CAP Robotics module abstract the hardware giving the same intuitive interface. for more details, see page 25.

CONFIGURATIONS

The ACTOR 2 can be attached to an XtaLAB Synergy Custom system with...

Sources available: FR-X, MM007

Detectors available: HyPix-6000HE, HyPix-Arc 100°, HyPix-Arc 150°



XtaLAB Synergy-ED

Electron diffraction made easy

Researchers are always pushing boundaries, and crystallography is no exception. In the quest to measure structural data from smaller and smaller samples, X-rays have their limits. Electron diffraction offers the chance to enter the realm of nanocrystallography and measure diffraction data from samples smaller than 1 micron.

Rigaku has partnered with JEOL Ltd. to bring you an easy-to-use electron diffractometer designed with crystallographers in mind, the XtaLAB Synergy-ED.

The XtaLAB Synergy-ED is a highly stable and precise electron diffractometer featuring electron control and generation technology from JEOL Ltd. and the HyPix-ED and CrysAlis^{Pro} control software from Rigaku.

The combination of these key technologies from leaders in their respective fields has resulted in a truly powerful device for nanocrystallography.

STABILITY AND PRECISION

In electron diffraction, a stable, distortion-free electron beam and optical system is a must. Relying on their extensive experience in electron microscopy, our partners at JEOL Ltd. have produced a column optimized for diffraction that does not suffer from distortions like some electron microscopes do. Applying wisdom learned in the development of its many cousins in the microscopy field, the XtaLAB Synergy-ED has a vertical arrangement to ensure the stability of the electron beam over time.



HyPix TECHNOLOGY INSIDE

The XtaLAB Synergy-ED features Rigaku's HyPix-ED detector. Using the same technology as our highly respected HyPix detectors for X-ray diffraction and is optimized for the electron diffraction experiment.



CrysAlis^{Pro} ED

Control

As with all of our X-ray diffractometers, the XtaLAB Synergy-ED is controlled by CrysAlis^{Pro} ED for a consistent, familiar user experience. Existing CrysAlis^{Pro} users should be right at home and able to successfully collect and solve their first structure within minutes.

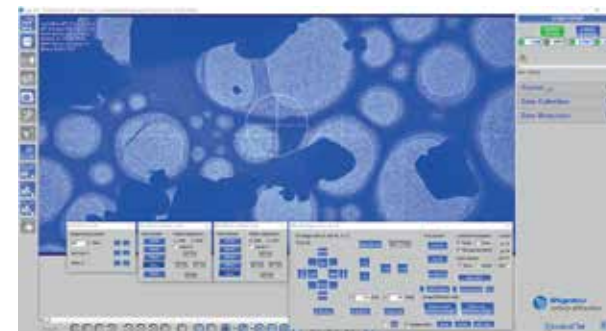

Data reduction

Features like concurrent data processing and AutoChem work for electron diffraction too. That means all of the data processing power you are used to in X-ray is available for electrons as well, and CrysAlis^{Pro} is under active development, particularly for electron diffraction so the only way is up.

A wide range of sample holders

The XtaLAB Synergy-ED is compatible with many existing sample holders used with TEMs. We are checking new holders frequently so check with us for more information.

HIGH QUALITY RESULTS

In the short time XtaLAB Synergy-ED has been operational, it has already collected hundreds of unique structures.

Results have already been published in high quality journals such as *Nature Communications*¹.

¹ Pearce et al. *Nature Communications*, 13, Article Number: 4115 (2022)

SELECTED ATTACHMENTS FROM RIGAKU*

The XtaLAB Synergy platform is designed to be versatile with a variety of attachments and upgrades to extend the functionality of your instrument allowing you to achieve more.

With attachments including automation products like the XtalCheck-S, an *in situ* SBS plate screener and the Intelligent Goniometer Head (IGH), you can get more done more easily.

Our high pressure kits allow you to accommodate the largest diamond anvil cells—as well as other bulkier equipment—to enable your move into crystallographic research under extreme conditions.

XtalCheck-S

The XtalCheck-S is a motorized screening device offering *in situ* screening of crystals or powders in crystallization plates. Queue up objects to screen with a simple point-and-click interface and let the instrument automatically screen them while you focus on other things. Fast motors traverse the entire plate quickly to make sure you can set up your scans fast and leave the system to it.



Originally designed for use in protein crystallography, it can also be applied to small molecule samples when used with solvent-resistant plates or for powder screening. The device can be attached to the instrument in under five minutes, and mounting crystallization plates is an easy one-handed operation.

HIGH-PRESSURE KITS

Accommodating the vast majority of commercially available and custom high-pressure cells, the high-pressure kit creates a sample space with an 8 cm diameter. It is easy to switch between high pressure and standard mode and, with powerful high-pressure software tools to aid with data analysis and processing, high-pressure experiments have never been easier.



INTELLIGENT GONIOMETER HEAD 2

Our Intelligent Goniometer Head (IGH) is a motorized marvel, with a slender profile and packed with great tech. Using artificial intelligence, samples can be automatically optically centered, or centered using X-rays for the most challenging cases. The IGH 2 features encoded motors enabling precise positioning, so it's possible to scan the sample for maximum diffracted intensity before returning to the optimal position. Its built-in magnetic mount is compatible with common pin standards such as the SPINE and ALS.

The updated body shape is even slimmer than the original IGH, increasing the achievable scan ranges in your experiment.



LOW TEMPERATURE ATTACHMENTS FROM OXFORD CRYOSYSTEMS

The All New Cryostream 1000



CrysAlis^{Pro} is ready for the next generation Cryostream 1000 from Oxford Cryosystems. With full support for control over ethernet, you can automate variable temperature experiments, anneal samples or simply shutdown your Cryostream at the end of your experiment to conserve LN₂.

Go Ultra-Low with the N-HeliX

The N-HeliX from Oxford Cryosystems allows you to go to lower temperatures, beyond liquid nitrogen temperatures, down to 30 K. Our N-HeliX solution



fits within the normal system footprint. The stand is discretely integrated into the cabinet yet is isolated from the enclosure to ensure no vibrations are transmitted to the instrument. You can also dual-mount the N-HeliX alongside a second low temperature device for flexibility.

HIGH TEMPERATURE DEVICE FROM FMB OXFORD

When you want to go to high temperatures for materials research or similar techniques, XtaLAB Synergy diffractometers can be ordered with compatibility to devices like the FMB Oxford Gas Blower. The Gas Blower offers temperatures up to 1000°C.



SELECTED THIRD-PARTY ATTACHMENTS*

The XtaLAB Synergy platform is compatible with a variety of popular third party attachments, including popular nitrogen and helium devices from Oxford Cryosystems.

For those customers interested in collecting data at non-ambient temperatures, a range of attachments are available allowing you to measure from 30 K up to 1273 K depending on the devices chosen.

Integrated software control of the most common low devices enables automatic variable temperature experiments or simple shutting down at the conclusion of your data collection to conserve resources.

*Ask us for a full list of supported attachments

CrysAlis^{Pro}

USER INSPIRED SOFTWARE

Combining and harnessing the expertise of our customers as well as our staff is clearly a winning formula. Using this approach, CrysAlis^{Pro} has been shaped over the years to become one of the most highly regarded, user friendly, and complete crystallographic software packages in the world. After all, what good is a powerful diffractometer you can't use effectively?

CONSISTENT AND RELIABLE

Whether you are using a rotating anode, a sealed tube or our new electron diffractometer, CrysAlis^{Pro} offers a consistent interface so you can feel at home and use the full power of your hardware without learning anything new.

CrysAlis^{Pro} is a single integrated package for both diffractometer control and data analysis. Automated analysis of the data can thus be conducted parallel to the ongoing data collection with near-instant experiment feedback. Novices and experts alike can use it immediately, with full automation for ease of use and fully manual control when you need it.

FAST RELIABLE FEEDBACK

- Unit cells typically can be determined within one or two frames and can be searched for via CellCheckCSD or a local database automatically.
- “What is This?” tool can determine connectivity in seconds, allowing you to make fully informed decisions without wasting valuable instrument time.
- A wide variety of tools are available to assist you in visualizing, identifying and solving problems quickly.

Key Features

- 64-bit compatibility—access more memory for faster processing and handling bigger datasets
- Ewald3D—a fast 3D diffraction viewer
- More hardware support than ever before

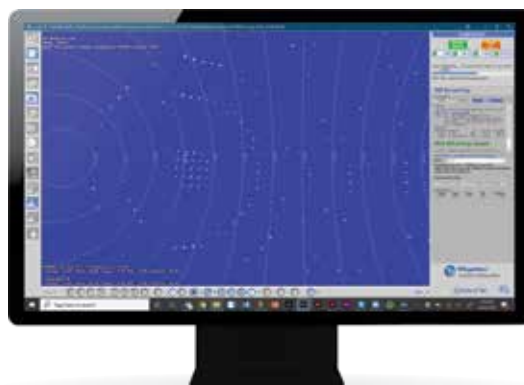

SM OR PX

We understand that the small molecule and protein communities have key differences in the way they approach the subject of data collection and processing. CrysAlis^{Pro} contains separate workflows to fit their differing needs and approaches. Use our powerful data processing suite or export your frames for processing in an external package, it's up to you. When installed, CCP4 is automatically recognized and CrysAlis^{Pro} can prepare data for it.

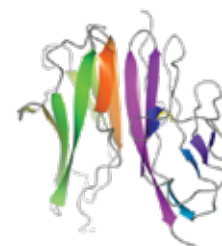

CrysAlis^{Pro} PX

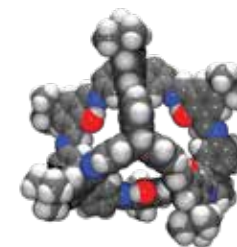

CrysAlis^{Pro} SM

Common small molecule refinement packages are also automatically detected and can be launched via CrysAlis^{Pro}, ensuring your data stays in sync.

FAST SUPPORT AND SOLUTIONS

CrysAlis^{Pro} facilitates effective remote support, both scientific and technical, with full diagnostic readouts and detailed log files for remote diagnosis and solving of issues. We often can diagnose and assist without need for a site visit, getting you back up and running fast.

“WHAT IS THIS?”

“What is this?” offers the possibility to see your structure within seconds or minutes depending on the quality of your sample. We call this interactive crystallography.

Interactive crystallography allows you to make informed decisions based on structure, not just statistics, to direct your research.

When ready, the structure can be used in planning better experiments with more certainty.

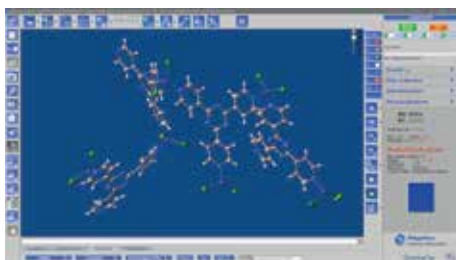

STRUCTURE EXPLORER

The advantage of all-in-one software is that knowledge of the experiment is available to all parts of the crystallographic process. StructureExplorer extends this into structure solution and refinement. Using a simple intuitive interface, users can solve, refine and edit structures within CrysAlis^{Pro}. Our checklist feature alerts novice crystallographers to common issues, how to fix them and even links you directly to the CrysAlis^{Pro} module needed to analyze or rectify them.

ROBOTICS

For our new XtaLAB Synergy Flow and IGH products, CrysAlis^{Pro} has added a new CAP Robotics module.

With simple, visual sample selection and queuing, CAP Robotics lets you quickly and easily set up your instrument to run a whole queue of experiments so you can run your instrument unattended, ensuring the maximum output from your instrument day and night.



IMPORT DATA

CrysAlis^{Pro} features our “Esperanto” importer to allow you to look at data from other sources. With a little knowledge of the instrument you are importing data from, the importer lets you define the needed information and read in data to be processed with CrysAlis^{Pro}. Whether you are a frequent synchrotron user or just looking to ease your transition to Rigaku Oxford Diffraction, the importer allows you to use one software suite for all of your datasets.

EWALD 3D

Ewald 3D gives you a 3D view of the real diffraction intensities. See artifacts like twinning, incommensurate behavior, or other unindexed intensity in a simple, visual way.

You can even use Ewald 3D live during the experiment on some instrument configurations so that you can watch the data as it comes in so you can see problems as early as possible to avoid wasted diffractometer time.

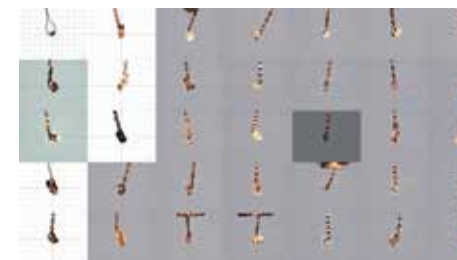

AI INSIDE

AI Image processing is just one example of the artificial intelligence present in CrysAlis^{Pro}. Our software seeks not only to make your life easier with AI but also to improve outcomes.

Above are many examples of successful automatically centered samples using AI and our IGH motorized goniometer head.

Notes



